

CONCEPTUAL ONLY

SIGN OFF WILL BE REQUIRED AFTER TIME OF ORDER
A NEW PRINT WITH ML NUMBER
WILL BE SUBMITTED FOR APPROVAL AFTER ORDER IS PLACED

NOTES:

- 1) ALL DIMENSIONS FOR REFERENCE ONLY
- 2) ALL DIMENSIONS SUBJECT TO CHANGE PENDING FINAL DESIGN
- 3) SLIDES ASSEMBLED COMPLETELY BUT SYSTEM SHIPPED AS A KIT
- 4) MOTOR, GEARHEAD AND CABLE CARRIER DIMENSIONS MAY VARY DUE TO VENDOR SUPPLIED MODELS

PRE-PRODUCTION RELEASE	ETB	12-11-24				
REV	CHG	DESCRIPTION	BY	DATE	CHKD	DOC NO
<p>phd THIS DOCUMENT IS THE PROPERTY OF PHD, INC. AND CONTAINS PROPRIETARY AND CONFIDENTIAL INFORMATION. THIS DOCUMENT REGARDLESS OF FORMAT OR MEDIUM IS LOANED WITH THE EXPRESS UNDERSTANDING THAT NEITHER IT NOR THE INFORMATION CONTAINED THEREIN SHALL BE DISCLOSED WITHOUT THE WRITTEN CONSENT OF PHD, INC. AND THAT THE INFORMATION SHALL BE USED BY THE RECIPIENT ONLY AS APPROVED EXPRESSLY BY PHD, INC. THIS DOCUMENT SHALL BE RETURNED TO PHD, INC. UPON REQUEST. © COPYRIGHT BY PHD, INC. ALL RIGHTS RESERVED.</p>						

ALL DIMENSIONS ARE REFERENCE ONLY UNLESS OTHERWISE NOTED

ASME Y14.5M - 1994
THIRD ANGLE PROJ

REMOVE BURRS AND BREAK ALL EDGES .015 MAX | SCALE: 1:10

TITLE: CATALOG DIMENSIONS

FIRST USED ON: MODULAR 3-AXIS ASSEMBLY

BY: DSG
ETB 12-11-24

DATE: 12-11-24

BY: DWG
ETB 12-11-24

CHK

MATERIAL:	-----
HEAT TREAT:	
FINISH/PLATING:	
TYPE OF CHANGE:	BY:
DRAWING NO. B- 320625-99	SHEET NO: 1

DRAWING NO.
B- 320625-99

SHEET NO: 2

REV

BOOK NO:

 EXTRUSION DIMENSION

 MANDATORY CHAMFER

 MODIFY

 CUSTOMER SPECIFICATION

SIMILAR TO:
REPLACES:

DRAWING TYPE:
DRAWN AS:

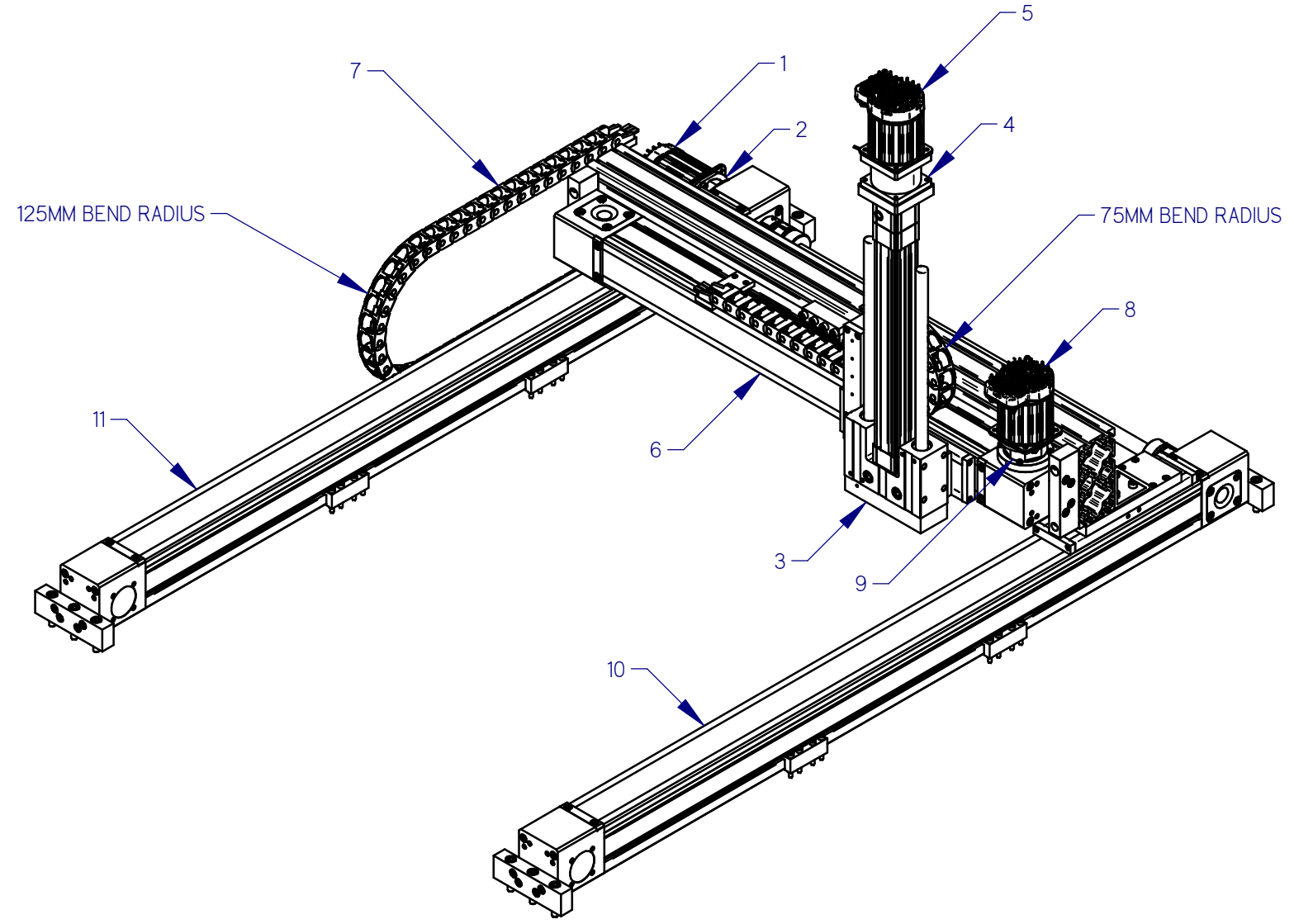

PART LIST	
PART NUMBER	PART
1	MOTOR X-AXIS
2	HALLOWBORE 5:1 GEARBOX (X)
3	ESKB55X300-RB010-QL11-W0687
4	MOTOR BRAKE
5	MOTOR Z-AXIS
6	ESUS56X550-RT192-QLT1-KS111
7	CABLE MANAGEMENT
8	MOTOR Y-AXIS
9	HALLOWBORE 5:1 GEARBOX (Y)
10	ESUS56X1050-RT192-QLT1-KS121
11	ESUS56X1050-RT192-QLTD-KS121

PRELIMINARY COPY

						ALL DIMENSIONS ARE REFERENCE ONLY UNLESS OTHERWISE NOTED		ASME Y14.5M - 1994 THIRD ANGLE PROJ		MATERIAL:															
						REMOVE BURRS AND BREAK ALL EDGES .015 MAX		SCALE: 1:10		HEAT TREAT:															
PRE-PRODUCTION RELEASE						ETB 12-11-24		BY: DSG ETB 12-11-24		FINISH/PLATING:															
<table border="1"> <thead> <tr> <th>REV</th> <th>CHG</th> <th>DESCRIPTION</th> <th>BY</th> <th>DATE</th> <th>CHKD</th> <th>DOC NO</th> </tr> </thead> <tbody> <tr> <td></td> <td></td> <td></td> <td></td> <td></td> <td></td> <td></td> </tr> </tbody> </table>						REV	CHG	DESCRIPTION	BY	DATE	CHKD	DOC NO								TITLE: CATALOG DIMENSIONS		DATE: 12-11-24		TYPE OF CHANGE:	
REV	CHG	DESCRIPTION	BY	DATE	CHKD	DOC NO																			
						FIRST USED ON: MODULAR 3-AXIS ASSEMBLY		BY: CHK		DRAWING NO. B- 320625-99															
										SHEET NO: 2															